

SAP Manufacturing Execution
How-To Guide



How To Set Up and Use the SAP ME Nonconformance Feature

Applicable Release: ME 6.0

Version 1.1

July 10, 2013

SAP ME How-To-Guide for Nonconformance

© Copyright 2013 SAP AG. All rights reserved.

No part of this publication may be reproduced or transmitted in any form or for any purpose without the express permission of SAP AG. The information contained herein may be changed without prior notice.

Some software products marketed by SAP AG and its distributors contain proprietary software components of other software vendors.

Microsoft, Windows, Outlook, and PowerPoint are registered trademarks of Microsoft Corporation.

IBM, DB2, DB2 Universal Database, OS/2, Parallel Sysplex, MVS/ESA, AIX, S/390, AS/400, OS/390, OS/400, iSeries, pSeries, xSeries, zSeries, z/OS, AFP, Intelligent Miner, WebSphere, Netfinity, Tivoli, Informix, i5/OS, POWER, POWER5, OpenPower and PowerPC are trademarks or registered trademarks of IBM Corporation. Adobe, the Adobe logo, Acrobat, PostScript, and Reader are either trademarks or registered trademarks of Adobe Systems Incorporated in the United States and/or other countries.

Oracle is a registered trademark of Oracle Corporation.

UNIX, X/Open, OSF/1, and Motif are registered trademarks of the Open Group.

Citrix, ICA, Program Neighborhood, MetaFrame, WinFrame, VideoFrame, and MultiWin are trademarks or registered trademarks of Citrix Systems, Inc.

HTML, XML, XHTML and W3C are trademarks or registered trademarks of W3C®, World Wide Web Consortium, Massachusetts Institute of Technology.

Java is a registered trademark of Sun Microsystems, Inc.

JavaScript is a registered trademark of Sun Microsystems, Inc., used under license for technology invented and implemented by Netscape.

MaxDB is a trademark of MySQL AB, Sweden.

SAP, R/3, mySAP, mySAP.com, xApps, xApp, SAP NetWeaver, and other SAP products and services mentioned herein as well as their respective logos are trademarks or registered trademarks of SAP AG in Germany and in several other countries all over the world. All other product and service names mentioned are the trademarks of their respective companies. Data contained in this document serves informational purposes only. National product specifications may vary.

These materials are subject to change without notice.

These materials are provided by SAP AG and its affiliated companies ("SAP Group") for informational purposes only, without representation or warranty of any kind, and SAP Group shall not be liable for errors or omissions with respect to the materials. The only warranties for SAP Group products and services are those that are set forth in the express warranty statements accompanying such products and services, if any. Nothing herein should be construed as constituting an additional warranty.

These materials are provided "as is" without a warranty of any kind, either express or implied, including but not limited to, the implied warranties of merchantability, fitness for a particular purpose, or non-infringement.

SAP shall not be liable for damages of any kind including without limitation direct, special, indirect, or consequential damages that may result from the use of these materials.

SAP does not warrant the accuracy or completeness of the information, text, graphics, links or other items contained within these materials. SAP has no control over the information that you may access through the use of hot links contained in these materials and does not endorse your use of third party web pages nor provide any warranty whatsoever relating to third party web pages.

SAP ME "How-to" Guides are intended to simplify the product implementation. While specific product features and procedures typically are explained in a practical business context, it is not implied that those features and procedures are the only approach in solving a specific business problem using SAP ME. Should you wish to receive additional information, clarification or support, please refer to SAP Consulting.

Document History

Document Version	Description	Author
1.0	Initial version	Charlie Cutler
1.1	Clean up – broken links, etc.	Chet Moutrie

Table of Contents

1	Introduction	1
1.1	Purpose	1
1.2	Scope.....	1
2	Nonconformance (NC) Feature Overview.....	1
2.1	Description and Applicability	1
2.2	Business Purposes / Functions.....	2
2.3	Implementation Considerations	2
2.4	Prerequisites	3
2.5	Best Practices	4
3	Nonconformance Functions.....	4
3.1	Log NC Features	4
3.1.1	Description and Applicability	4
3.1.2	Purpose / Effects.....	4
3.1.3	Process Flow.....	5
3.1.4	Data Model.....	6
3.2	NC Selection, NC Data Entry and NC Tree (Function)	6
3.2.1	Description and Applicability	6
3.2.2	Data Flow	7
3.2.3	NC Selection	9
3.2.4	NC Data Tree.....	9
3.2.5	Data Model.....	11
3.3	Perform Analysis and Repair (Function)	11
3.3.1	Description and Applicability	11
3.3.2	Purpose / Effects.....	12
3.3.3	Best Practices	12
3.3.4	Process Flow.....	14
3.3.5	Additional Example	14
3.3.6	Verifying Defects.....	15
3.4	Setting Up Log NC Clients (Process).....	16
3.4.1	Description and Applicability	16

SAP ME How-To-Guide for Nonconformance

3.4.2	Purpose / Effects	16
3.4.3	Best Practices	16
4	Integration	20
5	Log NC Setup and Configuration	20
5.1	Maintenance Activities	20
5.1.1	System Rule Maintenance	20
5.1.2	Routing Maintenance.....	20
5.1.3	Data Field Definition Maintenance	21
5.1.4	Data Field Assignment Maintenance	21
5.1.5	Default Value Maintenance	21
5.1.6	NC Code Maintenance and NC Group Maintenance	22
5.1.7	Product Configuration.....	22
6	Log NC Reject	24
6.1	Use	24
6.2	LogNC_Reject Activity ID.....	25
6.3	Activity Group Assignment	25
6.4	Log NC Reject Configuration	25
6.4.1	Can be defined as a standalone alone button.	25
6.5	Maintenance Business Rules affecting Log NC Reject	25
6.5.1	POD Maintenance	25
6.5.2	NC Code Maintenance	25
6.5.3	Default NC Code.....	25
6.5.4	Data Type Maintenance.....	27
6.5.5	System Rules	27
6.6	Standalone NC Logging Client	28
7	Links to Additional Information	28
8	Other Reference Material	29
9	Overview of Changes	30

1 Introduction

1.1 Purpose

The ME Help How-To-Guide for the Log Nonconformance (Log NC) feature is intended to provide sufficient information to enable the feature to be easily configured and readily utilized to meet business needs, making use of available best practices.

1.2 Scope

This Help information covers all aspects of the Log NC feature and its integration with other features and Activities. This document does not describe the Log NC configuration and use as it pertains to Shop Workbench or VTR POD; please refer to the Shop Workbench How to Guide and the VTR How to Guide for information on their usage. Where appropriate, links to other SAP ME Help documents will be italicized.

2 Nonconformance (NC) Feature Overview

2.1 Description and Applicability

The Nonconformance functionality provides a mechanism for the logging, tracking and dispositioning of failed or defective parts or assemblies. It allows you to do the following:

- With the help of closed loop system, document the Nonconformance Management process
- Expedite the disposition of nonconforming parts / material
- Ensure that the appropriate resources receive nonconformance work tasks for which they have been designated and provide traceability

At various steps on your routings, there are operations where a product is tested or inspected for quality standards. When a product does not comply with a quality specification, the operator or machine at that step logs one or more nonconformances (NCs) against that particular SFC number.

You can log a nonconformance code for a product defect. This includes test or product quality defects, such as a scratch on a chassis.

When an operator logs an NC code, the definition of the NC code determines the disposition of the SFC number to one of the following locations:

- The first step on a disposition routing
- Disposition group options
- Another step on the current routing for analysis or repair

Operators at these steps can log additional NCs against the SFC number to detail its current condition.

2.2 Business Purposes / Functions

The purpose of the Nonconformance functionality is to provide a mechanism for the logging, tracking and dispositioning of failed or defective parts or assemblies. The nonconformance functionality is highly configurable and tightly integrated with other functions and activities in SAP ME. It provides a closed loop system which documents the Nonconformance Management Process, expedites the disposition of nonconforming Parts / Material, ensures that the appropriate resources receive nonconformance work tasks for which they have been designated and provides traceability.

2.3 Implementation Considerations

When you set up nonconformance, you must decide:

- How you want routing branching and dispositioning to behave in the system (see *Branching with Nonconformance Codes and Scripting, Nonconformance Dispositioning* in SAP ME 6.0 Help).
- What information you want to collect for analysis, integrity checking, and other uses when operators log nonconformance's
- Which nonconformance codes you want operators to use when they log NCs, and how you want to organize them (see *NC Code* in SAP ME 6.0 Help)
- How you use real-time warnings (see *Real Time Warning Maintenance* in SAP ME 6.0 Help)
- How you want the Production Operator Dashboard (POD) to behave and appear for operators who log nonconformance's (see *Setting up PODs for Nonconformance* in SAP ME 6.0 Help)
- How you use DPMO (see *DPMO* in SAP ME 6.0 Help)
- If you want to use Log NC Reject vs. Log NC or both or Standalone NC Logging

Integration

If you use the SAPMEINT component, see *Transfer of Nonconformance Data to Quality Notification* in SAP ME 6.0 Help

Additionally LOG NC integrates the VTR Model Viewer (See *SAP ME How-To-Guide - VTR*) and Sampling (See *SAP ME How-To-Guide - Sampling*) components with the following Nonconformance Management plug-ins:

- NC Data Entry (see [NC Data Entry](#))
- NC Selection (see [NC Selection](#))
- NC Tree (see [NC Data Tree](#))

In a POD configured with LOG NC, when the user selects an SFC number the Model Viewer displays the graphical model specified for the associated material. Selecting an element in the Model Viewer populates fields in the *NC Data Entry* plug-in. Specifying values in the NC Data Entry plug-in fields highlights the corresponding element in the Model Viewer. Similarly,

selecting a logged NC Code in the *NC Tree* plug-in highlights centers and zooms the corresponding element in the Model Viewer.

2.4 Prerequisites

You have defined Work Instructions in **Work Instruction Maintenance**. Work Instructions should be created and attached where necessary if they are to be used with the NC Client. (See *Work Instruction Maintenance* in ME Help)

You have defined Disposition and other Nonconformance routings in **Routing Maintenance**. Your businesses routing needs should be defined for all needed nonconformance scenarios prior to using the NC functionality. Proper NC Routing, Disposition Routing and any other special routing should be created and applied to the NC Client, Disposition Group or Operation etc as is necessary. (See also *Routing Maintenance* in ME Help)

You have defined Disposition Groups and their functions and any special "Routing" considerations in **Disposition Group Maintenance**. For Example: define LOCAL_REWORK, as a Disposition Group that identifies the processes and steps needed to support reworking a product defect at the location where the defect was discovered. Some Disposition Groups are included by default and may be used as a starting point for creating similar disposition groups. (See also *Disposition Group Maintenance* in ME Help)

You have defined the look and feel of the Log NC GUI in **NC Client Maintenance**. You can define the NC Selection and NC Data Entry plug-in views. You can define the behaviors and interactions for other integrated NC Plug-ins such as; NC Data Tree and NC Charts and for the Work Instruction Plug-in. You can also define whether Primary and Secondary NC Codes can be logged and specify the component routing. Several NC Clients have been configured and applied to other POD's by default. These Clients have been created to support standard Log NC business process scenarios for several manufacturing scenarios, including simple and complex manufacturing and assembly. These default NC Clients may be used as-is or as a starting point for creating new NC Clients for similar NC Logging needs. (See also *NC Client Maintenance* in ME Help)

You have defined the NC Codes needed for logging of Primary, Secondary and Repair type codes in **NC Code Maintenance** (See also *NC Code Hierarchy* in ME Help). You can define if an NC Code is to be a Primary, Secondary or Repair code; how to route the SFC (disposition) due to the NC code being logged. If the NC Code is defined as a Primary, you may identify those codes that are subordinate to those primaries (secondary defect codes or repair codes). Similarly, you can identify the repair codes that can be used for a secondary defect code. Many NC Codes that have been included by default to support the nonconformance processing needs of most manufacturing or assembly type customers. These may be used as-is or as a starting point to create similar NC Codes.

You have defined the appropriate NC Groups in **NC Group Maintenance**. You use this activity to assign NC codes to an NC group (see also *NC Code* in ME Help). This activity allows you to do the following: create NC groups, define operations where the NC group is available, and override system rules at the NC group level.

You have defined PODs in **POD Maintenance**. NC Clients are assigned to the POD, and a mechanism to launch the NC Client plug-ins should be available for the POD (Button or Button Group Activity defined). By default, the standard NC Client plug-in has been configured into the default Operation POD and the default Work Center POD. (See also *POD Maintenance* in ME Help).

2.5 Best Practices

We recommend that the Nonconformance plug-ins are to be configured to be run in an Operation POD, Work Center POD or in a Standalone NC Logging configuration.

3 Nonconformance Functions

3.1 Log NC Features

3.1.1 Description and Applicability

LOG NC can be used to log primary and secondary NC Codes against an SFC number from the Operation POD.

The LOG NC feature facilitates the logging of NC codes with the correct data. For more information, see *Select NC Code*.

Once a Failure NC Code has been logged and is displayed in the NC Tree, LOG NC can be used to facilitate the analysis of the Failure and the logging of one or more Defect NC Codes. Similarly, for each Defect NC Code that has been logged and is displayed in the NC Tree, LOG NC facilitates the logging of a Repair NC Code. For more information, see *Log and View NC Code, and Test/Inspection Failure*.

3.1.2 Purpose / Effects

You can use the *Log Nonconformance* (LOG NC) feature to record the **NC** codes resulting from the testing / inspection, analysis and repair of PCA boards or other materials. The Nonconformance feature helps you improve product quality and customer responsiveness by allowing you to do the following:

- Track failure, defect, and repair information about SFC numbers (see *SFC Numbers* in SAP ME 6.0 Help).
- Control the disposition of nonconforming products.
- Assign incident numbers to logged nonconformances.

SAP ME How-To-Guide for Nonconformance

- Calculate defects with the standardized DPMO (defects per million opportunities) methodology as defined in the IPC-9261 standard for printed board assembly manufacturing.
- Display up-to-date engineering models and schematics graphically in the *Visual Test and Repair plug-in*

At various steps on your routings, you can include operations where a product is tested or inspected for defects. When a product does not meet a quality specification, the operator or machine at that step is nonconforming, or logs a nonconformance (NC) against that particular SFC number.

When an operator logs an NC, the system can automatically send the nonconforming SFC number to one of the following locations:

- The first step on a disposition routing
- A disposition function
- Another step on the current routing, for analysis or repair

Operators at these steps can log additional NCs against the SFC number to detail its current condition.

LOG NC enables electronics manufacturers, in particular printed circuit board assemblers, to log **defects** against printed circuit boards and their components. Discrete manufacturers can use it to log defects against assemblies and their component parts.

3.1.3 Process Flow

The following figure illustrates the primary flow of user actions when utilizing LOG NC to support the testing / inspection, analysis and repair of a PCA Board or a product assembly.

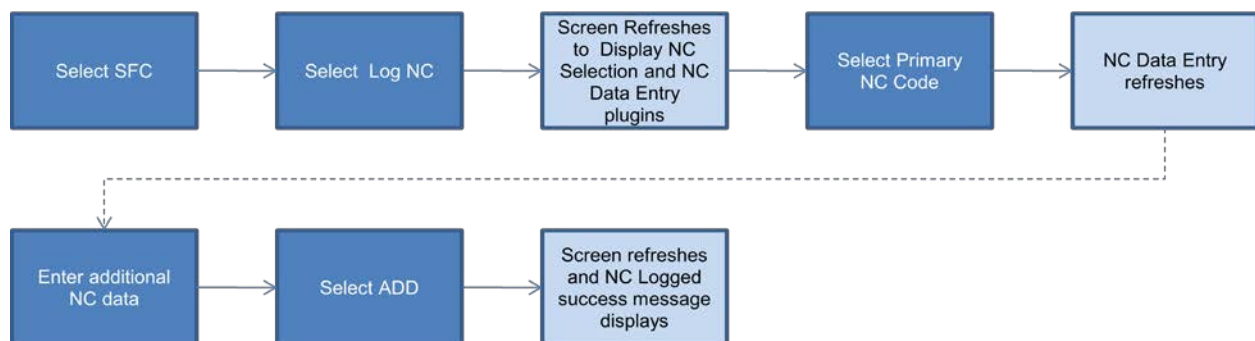

3.1.4 Data Model

The following figure shows the relationship between some of the LOG NC functions and ME database tables.

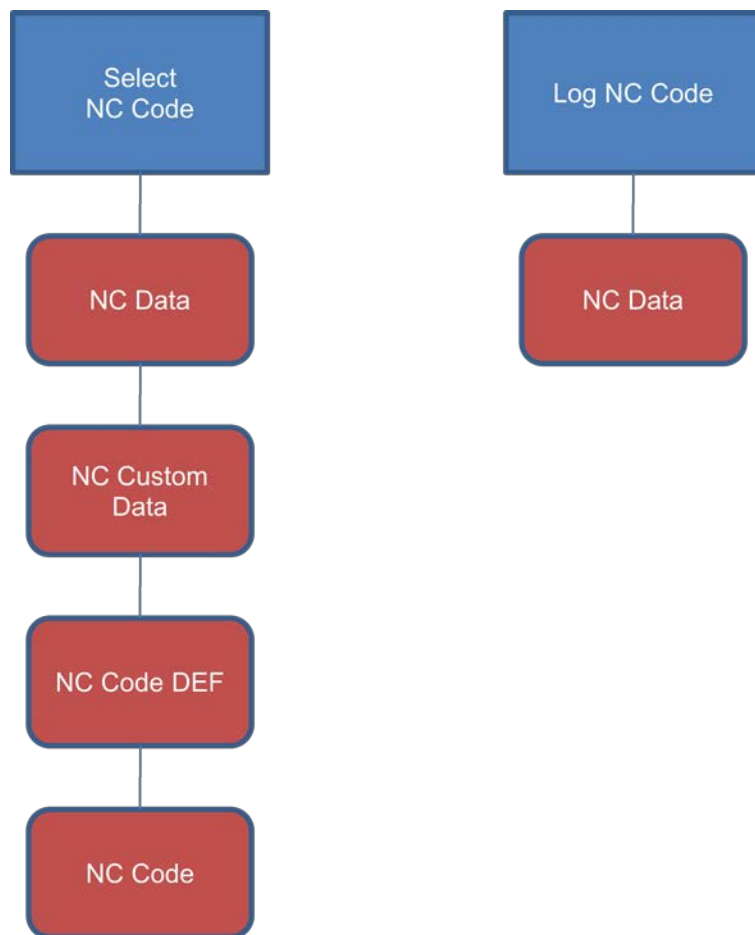

3.2 NC Selection, NC Data Entry and NC Tree (Function)

3.2.1 Description and Applicability

NC Selection POD plug-in displays the NC Codes available for selection. The NC Data Entry plug-in displays the information that needs to be entered (or has been entered) by the user. The Data Entry area is dependent on the NC Code selected. When a primary NC Code is already logged and is selected in the NC Tree, the NC Code Selection area will display the list of NC Codes available to log as a secondary NC Code for the primary NC Code. The content of the NC Selection and Data Entry areas are dependent on the NC Client that is assigned to the POD.

You use this function to log NC Codes against one or more selected SFC numbers in the POD.

Select NC Code

Selecting an NC Code, in the NC Selection plug-in, refreshes the NC Data Entry plug-in to display the Data Fields specified for that NC Code. For more information on NC Selection, see *Nonconformance (NC)* in SAP ME 6.0 Help.

It also populates the NC Code field in the NC Data Entry plug-in. At that point the user can change the selection via the NC Code Browse on the field. The user can enter any remaining required or optional Data. Once the desired data is entered, the User may complete the Log NC process by selecting the Add or Add/Done button in the NC Data Entry plug-in.

3.2.2 Data Flow

The following figure shows the relationship between some of the LOG NC functions and ME database tables.

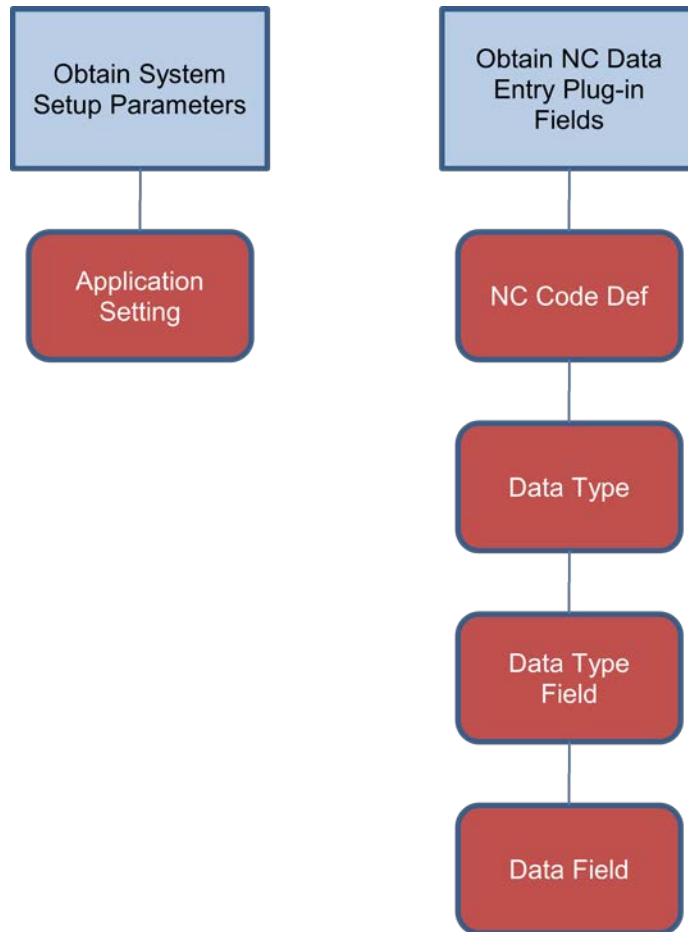

SAP ME How-To-Guide for Nonconformance

The table below describes some additional Rules to consider for NC Data Entry Activity in *Activity Maintenance*:

Main tab:

Activity	DATA_ENTRY_PLUGIN
Description	I18N[NC500.activity.DESC]Log NC
	Enabled
Class/Program	com.sap.me.nonconformance.client.impl.NCDataEntryPlugin
Type	Java Class

Rules Tab:

Rule	Setting
ALLOW_PARTIAL	<p>YES: The partial quantity processing of SFC number in the POD for immediate scrap is allowed.</p> <p>NO (default): The partial quantity processing of SFC numbers in the POD for immediate scrap is not allowed. The entire SFC quantity is dispositioned.</p>
PLUGIN_URL	<p>Specifies the plug-in location in the SAP ME folder structure</p> <p>Default value: /COM/SAP/ME/NONCONFORMANCE/CLIENT/NCDATAENTRY.JSP</p>
WORK_INSTR_PLUGIN_ID	<p>Default value: WI_LIST_DISPLAY. Specifies the work Instructions List plugin to be used in NC Client, where Work Instructions can be viewed.</p>

You can set a wide variety of options for *Log NC* in *Nonconformance Client Maintenance* (see *NC Client Maintenance* in SAP ME 6.0 Help).

3.2.2.1 Fields

The following tables describe some standard NC Data Entry elements displayed on the GUI, with further explanation:

Field	Description
<i>NC Code</i>	Displays the NC code selected for logging against an SFC number
<i>Comments</i>	Provides the ability to log comments associated with this SFC number. Can be later viewed from the <i>SFC Detail Report</i> .
<i>As-Built</i>	<p>Provides link to <i>As-Built Configuration</i> where you can optionally remove and add components</p> <p>Note that this link appears on the screen depending on the settings defined in <i>NC Client Maintenance</i> (see <i>NC Client Maintenance</i> in SAP ME 6.0 Help).</p>

SAP ME How-To-Guide for Nonconformance

<i>Add</i>	Logs a primary or secondary NC Code (Failure, Defect or Repair code).
<i>Add-Done</i>	Logs a primary or secondary NC Code, completes the session, disposes the SFC number (if enabled) and refreshes the NC Data Entry area and may refresh the NC Selection area.
<i>Work Instructions</i>	Displays the work instructions specified in <i>NC Client Maintenance</i>

3.2.3 NC Selection

You use this activity to view NC groups and available NC codes in the POD and *Standalone NC Logging*.

The following table describes rules and settings that you can change for this activity in *Activity Maintenance*:

Main tab:

Activity	NC_SELECTION
Description	I18N[NCSelection.activity.DESC] NC Selection
	Enabled
Class/Program	com.sap.me.nonconformance.client.impl.NCGroupListPlugin
Type	Java Class

Rules Tab:

Rule	Setting
DATA_ENTRY_PLUGIN_ID	Default value: NC_DATA_ENTRY. Rule setting to denote the NC Data Entry plugin used in the NC Pod.
PLUGIN_URL	Specifies the plug-in location in the SAP ME folder structure Default value: /COM/SAP/ME/NONCONFORMANCE/CLIENT/NCGROUPLIST.JSP

3.2.4 NC Data Tree

You use this activity to view information on the logged NC codes. The NC Data Tree displays the Logged NC Codes (Primary- Secondary) in a tree style format, where the tree shows the level of NC's logged against a particular SFC in a hierarchical tree format. The Nodes may be expanded or collapsed for viewing.

SAP ME How-To-Guide for Nonconformance

The following table describes rules and settings defined for this activity in *Activity Maintenance*:

Main tab:

Activity	NC_TREE
Description	I18N[NCTree.activity.DESC] NC Tree
	Enabled
Class/Program	com.sap.me.nonconformance.client.impl.NCDisplayPlugin
Type	Java Class

Rules Tab:

Rule	Setting
PLUGIN_URL	Specifies the plug-in location in the SAP ME folder structure Default value: /COM/SAP/ME/NONCONFORMANCE/CLIENT/NCDISPLAY.JSP

Prerequisites:

You have set up Nonconformance rules in System Rule Maintenance (See *System Rule Maintenance*).

Log and View NC Code (*Function*)

Logging NC code

To log an NC code, select the Add or the Add – Done button in the NC Data Entry plug-in. Log NC Code is a Nonconformance process that does not contain any LOG NC specific processing. For more information see *Nonconformance (NC)*.

Logging a Test / Inspection Failure

Logging a Failure in LOG NC consists of:

- Selecting a Failure NC Code (See *Select NC Code*)
- Entering required NC Data (See *NC Data Entry*)
- Logging an NC Code (See *Log NC Code*)

View Logged NC Code

Selecting a logged NC Code (existing row) in the *NC Tree* will refresh the NC Selection area to filter the list to display Secondary Codes. This function can be used to simply view the logged NC Code or it can be used as a starting point for performing Analysis (logging a secondary Defect NC Code) or logging a Repair NC Code. See [Perform Analysis and Repair](#) below.

SAP ME How-To-Guide for Nonconformance

The following figure illustrates the primary flow of user and system actions when an existing row in the *NC Tree* is selected and the user is logging a Secondary or repair NC Code.

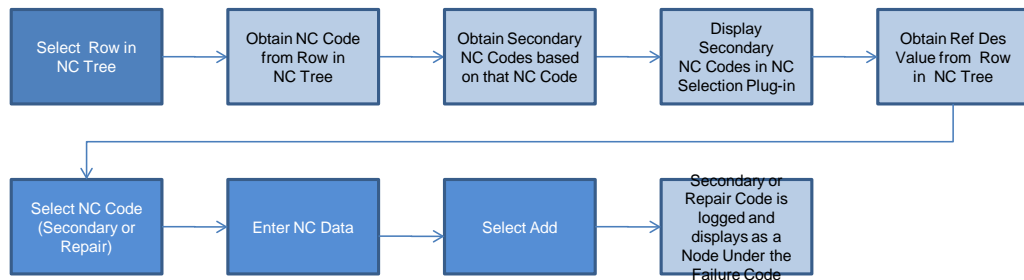

3.2.5 Data Model

The following figure shows the relationship between one of the LOG NC actions and related ME database tables for the Select Row in NC Tree process.

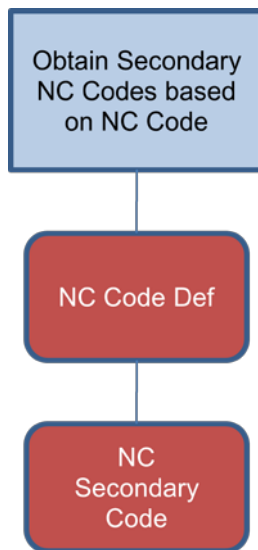

3.3 Perform Analysis and Repair (Function)

3.3.1 Description and Applicability

Once a failure NC Code has been logged, the user may need to perform some analysis to determine what Defect(s) caused the failure. Especially for PCA boards, LOG NC can facilitate this analysis. When a defect has been identified, LOG NC can facilitate the logging of the Defect NC Code.

User can also ensure that the appropriate element on the PCA board, or the appropriate part in an assembly, is repaired or replaced. When the appropriate repair action has been taken, LOG NC can facilitate the logging of the Repair NC Code.

3.3.2 Purpose / Effects

Perform Analysis – The PCA Layout and the Schematic Sheets in the ECAD model can be used to guide the user in analyzing potential causes of a test failure. This could include starting from the Test Point where the failure was detected and visually following the associated Route element to the components that might be faulty.

Log Defect Code – Once the defective element and cause have been determined, the user can select the appropriate NC Code and log the Defect NC Code.

Perform Repair –LOG NC can facilitate the performing of the repair action.

Log Repair Code – Once the repair action has been performed, the user can select the appropriate NC Code; select the ECAD model element, if needed; and log the Repair NC Code.

3.3.3 Best Practices

How Log NC Works (*Example*)

Test Failure, Analysis and Repair Scenario

There is a test failure for a PCA board. The failure must be analyzed and the cause logged as a defect. The appropriate disposition for the defect must then be determined and logged.

The following preconditions apply:

- Material ACME_PCB_3451 is a PCA board
- Operation PCB_TEST_ANALYZE_REPAIR is being performed at resource PCB_STATION
- A PCA board with SFC number ACME-3451-000004 is to be processed at this operation

In order to log all three types of NC Codes, the NC Client specified for the LOG NC POD must allow the logging of both Primary and Secondary NC Codes. To ensure this, select both of the following checkboxes on the main tab in NC Client Maintenance:

- Can Log Primary NC Code
- Can Log Secondary NC Code

Proceed as follows to log test failure:

1. Open the default Operation POD (POD – Operation)
2. Select operation PCB_TEST_ANALYZE_REPAIR
3. Select resource PCB_STATION
4. Select the browse for SFC numbers
5. Select SFC number ACME-3451-000004
6. Select the Start button to process ACME-3451-000004
7. External event – test fails at the bottom left test point with failure code F1-22

SAP ME How-To-Guide for Nonconformance

8. Select the FAIL NC code in NC Selection (displays fields in NC Data Entry)
9. Enter “Test P358 failed with failure code F1-22” in the Comments text box in the NC Data Entry plug-in
10. Enter the ref des value from the test point, in the Ref Des field in the NC Data Entry plug-in
11. Enter the Failure ID
12. Select the Add button in the NC Data Entry plug-in (logs the FAIL NC code)

To analyze and log defect, proceed as follows:

13. Select the NC Tree button in the POD (displays the NC tree in a pop-up window)
14. Select the row in the NC Tree and select the Return to POD button (displays the secondary NC code groups and codes in NC Selection)
15. External event – examination and test of component finds that the component has a bent lead that is not making contact
16. Select the COMPONENT NC group and the LEAD-BENT NC code in NC Selection
17. Enter the Ref Des information in the field (and 4399-3047-00 in the Component field in NC Data Entry)
18. Select the Add button in the NC Data Entry plug-in (logs the LEAD-BENT NC code)

To log Repair, proceed as follows:

19. External event – component is removed, repaired and reinstalled on the board
20. Select the NC Tree button in the POD (displays the NC tree in a pop-up window)
21. Select the row in the NC Tree with the LEAD-BENT NC code and select the Return to POD button (displays the REPAIRACTION NC code group and codes in NC Selection)
22. Select the DONE NC code in NC Selection (displays DONE in the NC Code field in NC Data Entry)
23. Select the Add button in NC Data Entry (logs the DONE NC code, and changes the NC state of the logged FAIL, LEAD-BENT and DONE NC Codes to Closed)

SAP ME How-To-Guide for Nonconformance

3.3.4 Process Flow

The following figure provides a high level flow of the LOG NC Test, Analysis and Repair example.

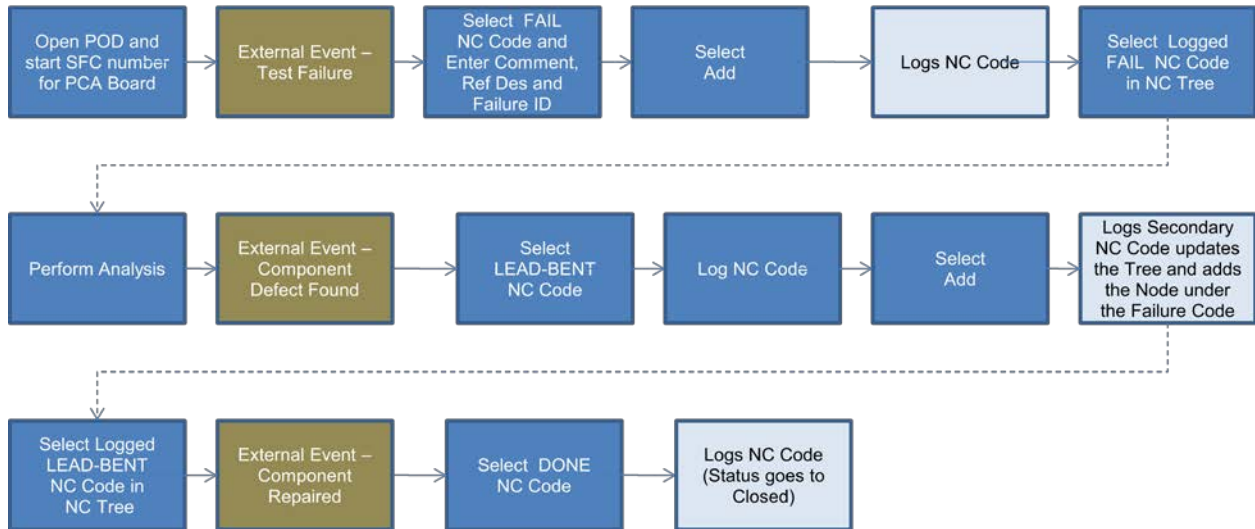

We recommend adding a comment field to the data type for the DONE NC code to enable the user to enter a comment regarding the specifics of the repair or the condition of the component.

3.3.5 Additional Example

The figure below shows a scenario for the standard nonconformance clients at different steps on the routing. In this case you use three separate operations for INSPECTION, DEBUG, and REPAIR on the routing:

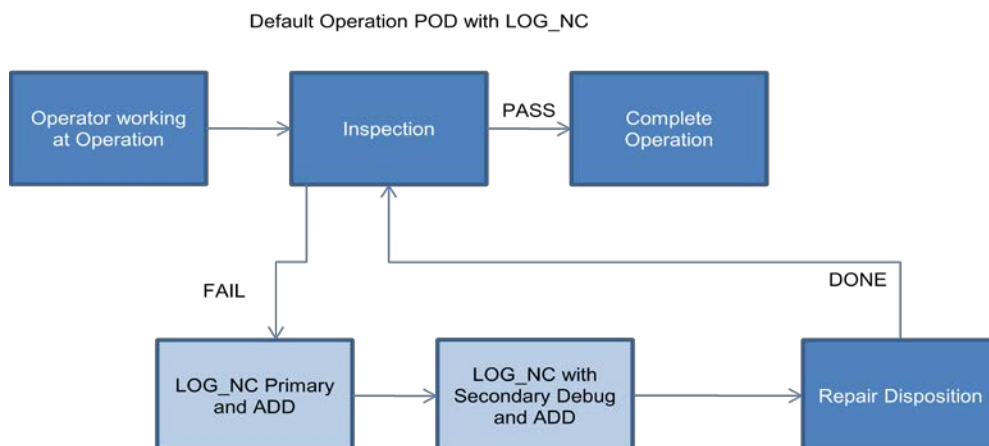

3.3.6 Verifying Defects

The system automatically logs a verified defect when a unit has moved through a repair loop and passed the test operation. As operators troubleshoot problems with units (SFC numbers) in a repair loop on your routing, they may log many failure, defect, repair cycles that do not fix the problem.

3.3.6.1 Example

The figure below illustrates the NC codes that operators may log during the first cycle through a repair loop:

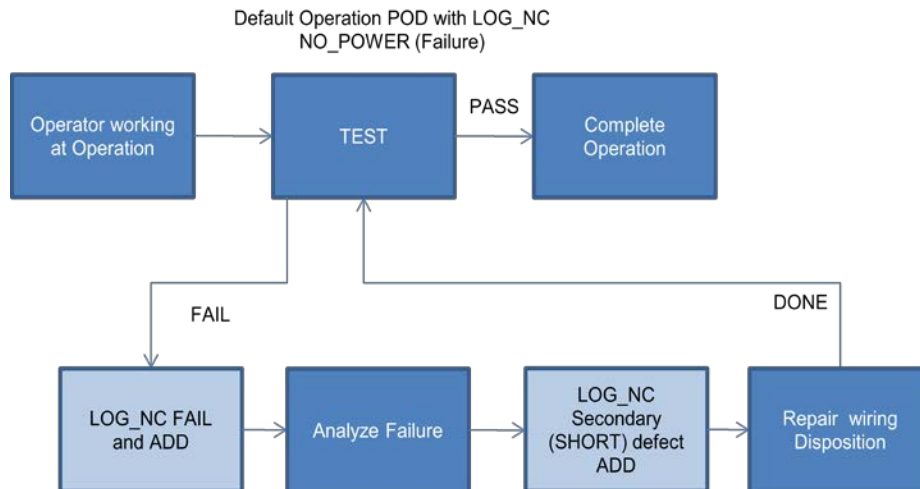

The figure below illustrates that when the unit is retested, it still fails:

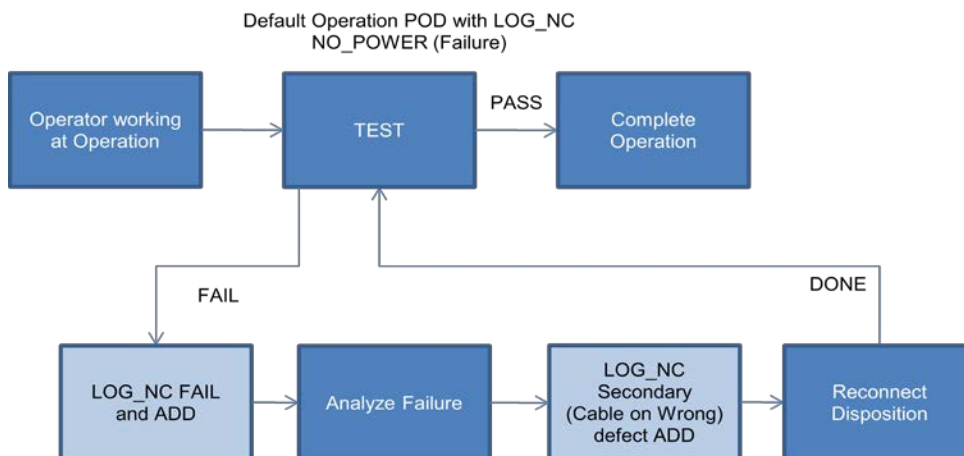

The SFC number is then sent through the repair loop again, and operators log other NC codes that reflect their actions the second time through.

SAP ME How-To-Guide for Nonconformance

The figure below illustrates that the unit is tested the third time and it passes:



The system logs the NO_POWER, CABLECONWRONG (Defect), and RECONNECT (Repair) sequence as the verified defect.

When a unit that has previously failed a test passes it, the last defect and repair logged against the unit indicates what was actually wrong with the unit and how it was repaired. This last defect and repair is then verified to be the actual case and is called a *verified defect*. Some nonconformance clients that come with the system display a *Verified Defects* chart to the operator in the POD. In *NC Client Maintenance*, you can create a nonconformance client that displays the *Verified Defects* chart.

3.4 Setting Up Log NC Clients (Process)

3.4.1 Description and Applicability

You can use these processes to set up LOG NC activity.

3.4.2 Purpose / Effects

In NC Client Maintenance there are several out of the box NC Clients that have been created in support of many simple to complex nonconformance business processes. Some examples of NC Clients are as follows:

FAILURE_TRACKING_STANDALONE	Standalone NC Logging Client
LOG_NC	Log NC Client
LOG_NC_W_SECONDARY	Log NC with Secondary Client
VISUAL_TEST_REPAIR	Visual Test and Repair Client

Each NC client has been configured to support a different type of nonconformance process and to behave uniquely when assigned to a POD.

3.4.3 Best Practices

It is important to understand how the system will respond to user action and processing while in a POD. We highly recommended that you use one of the existing clients to become familiar with the functions allowed. If you need additional NC clients you can create new NC Clients here or retrieve an existing NC Client and modify it to suit your needs.

SAP ME How-To-Guide for Nonconformance

An example of an NC Client is as follows:

NC Client – LOG_NC

Field	Value	Additional Information
Description	Log NC Client	This is the standard LOG NC client where only Primary NC's need to be logged.
Incident Number	None	<p><i>None:</i> Disables the incident number feature</p> <p><i>Manual:</i> Allows the operator to enter a value in this field</p> <p><i>Automatic:</i> Automatically populates a value in this field according to the incident number pattern defined in Next Number Maintenance. Operators can change the incident number that the system automatically enters in this field.</p>
Preload NC Fields	None	Defines which NC fields to preload from the primary NC when logging a secondary code
Component Disposition Routing	PMR	Specifies the disposition routing where the system sends the removed component
Select Default NC Code	Checked	If selected, automatically selects the default NC code in the <i>Available NC Codes</i> list.
Display Combined Add-Done Button	Checked	If selected, the <i>Add and Done</i> pushbutton appears in <i>Log NC (NC Data Entry)</i> and <i>Standalone NC Logging</i> .
Do Disposition	Checked	If selected, automatically dispositions the nonconformed SFC numbers or process lot

SAP ME How-To-Guide for Nonconformance

		based on the NC code configuration
Auto Remove/Replace NC Components	Unchecked	If selected, automatically removes and replaces the nonconformed SFC numbers or process lot based on the NC code configuration
Can Log Primary NC Code	Checked	Identifies that the client can be used to Log Primary (Failure) NC Codes against an SFC
Can Log Against Closed NC Code	Unchecked	If selected, operators can log an additional nonconformance against a failure, defect, or repair that has been logged and closed
Can Log Secondary	Unchecked	If selected, allows for logging of Secondary NC's (Defect) against a Primary (Failure)
Prompt to Log Secondary	Unchecked	If selected, the user is Prompted (via system message) to Log a Secondary
Display As-Built Link	Unchecked	If selected, link to the As-Built Record is displayed on the NC Data Entry plug-in
Display Work Instructions Button	Unchecked	If selected, link to the Work Instructions is displayed on the NC Data Entry plug-in
NC Selection Tab		
NC Code Display Criteria	NC Code	Sorts the Available NC Codes list in Log NC Client by NC code, NC code description or by NC code priority.
NC Group Column Heading	NC Group	Title of the column containing NC Groups in the NC Code Selection list
NC Code Column Heading	I18N[ncCode.default.BUTTON]	Title of the column containing NC Codes in the

SAP ME How-To-Guide for Nonconformance

		NC Code Selection list
NC Code Description in List	Unchecked	If selected, NC code descriptions appear in the Available NC Codes list
NC Data Tree		
NC Data Tree List	LOG_NC	The nonconformance list created in <i>List Maintenance</i> that appears in the <i>NC Data Tree</i> area of the <i>Log NC Client</i> The list controls the columns that appear and which order they appear in.
Expand NC Data Tree	Unchecked	If selected, automatically expands all nodes in the tree
Display Close All Open NCs Button	Unchecked	If selected, displays the CLOSE ALL button, which allows for all Open NC's to be closed at once when clicked
Allow Edit	Unchecked	If selected, displays the Edit link in the NC Tree, when clicked will open the EDIT NC function on the Data Entry plug-in allowing for changes to be made to the logged NC
NC Data Chart		
Number Of Verified Defect Bars	5	Displays the NC Defect Chart with bars (pareto). The value must be greater than 0
Display Component/Description	Unchecked	If selected, displays component and component description on the <i>Verified Defect Pareto</i> chart
Work Instructions		
Sequence	10	Identifies the order of the associated Work Instructions
Work Instruction		Allows for the assignment

		of specific Work Instructions to be assigned to the NC Client
Version		Displays the Version of Work Instructions assigned to the Client.

4 Integration

N/A

5 Log NC Setup and Configuration

5.1 Maintenance Activities

5.1.1 System Rule Maintenance

In *System Rule Maintenance*, you change any NC-related rule as required for your shop floor.

System rules define the overall guidelines by which the system operates (see also *Nonconformance Rules in ME Help* for more information on the settings and their meanings):

- Bypass Previous NC Routings on Return
- Generate and Lookup Vertical Ref Numbers
- Generate Horizontal Ref Numbers
- Maximum Loop Count
- NC Allows Non-BOM Component and Ref Des
- NC Allows Undefined Component
- NC Closure Required Default
- NC Unassembled BOM Components
- Use NC Groups for Production Clients

5.1.2 Routing Maintenance

In *Routing Maintenance*, you can:

1. Create repair loops.
2. Create disposition routings or set up function-based dispositioning.
3. Write scripts to automatically send nonconforming SFC numbers to a next step based on criteria.

5.1.3 Data Field Definition Maintenance

In *Data Field Definition Maintenance*, you define necessary fields and in Data Field Assignment Maintenance, you group these data fields and associate them with a data type of Nonconformance category. This will identify the data fields required or optional, for the data entry plug-ins for your NC Client.

In Data Field Definition Maintenance, you define the fields to be used for LOG NC Data Entry. For this, you can use pre-loaded REF_DES, COMMENTS, COMMENTS_REQ, FAILURE_ID, INVENTORY_ID, COMPONENT fields or define other fields. The data fields that are specified in the system settings property Log NC must already be defined in Data Field Definition Maintenance.

The Ref_Des and Component data fields are among the fields that are predefined. If a new data field is needed, fill in at least the following fields on the main tab:

- Data Field Name of the data field
- Type Select Text in the drop-down

5.1.4 Data Field Assignment Maintenance

In Data Field Assignment Maintenance, you associate these data fields with a data type of NC category (see Data Field Definition and Assignment). Other fields can also be included in this data type.

For the data fields to be utilized in LOG NC, they must be assigned to an NC data type in Data Field Assignment Maintenance.

Data types using the data fields Ref_Des and Component are included in the NC data types that are predefined. If a new data type is needed, fill in at least the following data type fields on the main tab:

- Category NC
- Type Enter the name of the data type

Use the Insert xxx action links to add the needed data fields to the data type and save the data type.

5.1.5 Default Value Maintenance

In *Default Value Maintenance*, you define the parameters and default values of NC codes for the NC Code table as follows;

Parent Table Name: **NC_CODE**

Column title	Default Value
ASSIGN NC TO COMPONENT	S
CAN BE PRIMARY CODE	True
CLOSURE REQUIRED	True
COLLECT REQUIRED NC DATA ON NC	O
MAXIMUM NC LIMIT (SFC)	0

SAP ME How-To-Guide for Nonconformance

NC CATEGORY	FAILURE
NC DATA TYPE	SIMPLE
NC PRIORITY	500
STATUS	301

5.1.6 NC Code Maintenance and NC Group Maintenance

In *NC Code Maintenance* and *NC Group Maintenance*, you do the following:

1. Group and create NC codes.
2. Categorize each NC code as a Failure, Defect, or Repair.
3. Assign NC data types to NC codes, if required.
4. Create primary and secondary NC codes according to the NC hierarchy you want to use on your floor.
5. Assign DPMO categories to NC codes, if required.
6. Set up activity hooks for NC codes.

In *NC Code Maintenance*, you assign NC data types, which contain fields mapped to LOG NC Data Entry elements, to NC codes.

Each NC Code must have an associated Data Type. The data type identifies the data entry fields to be displayed in the NC Data Entry plug-in for the NC Code. If you need to define a new NC Code, see *NC Code Maintenance* in ME Help.

To specify the ME Data Type for an NC Code, retrieve the NC Code in NC Code Maintenance and select the desired data type using the browse for the field on the main tab.

5.1.7 Product Configuration

In *POD Maintenance*, create a pushbutton associated with *Log NC* activity (LOG_NC) and assign it to your layout (see *Adding POD Pushbutton Activities to Your PODs* in SAP ME 6.0 Help).

A POD with at least the following plug-ins is needed in order to utilize LOG NC:

- NC Selection
- NC Data Entry

Optionally

- Model Viewer (See *Setting up Visual Test and Repair (VTR)* in the SAP ME 6.0 Help)
- NC Tree

In order to log Defects or Repairs, the NC Tree plug-in is also needed.

A default LOG NC Client is predefined in ME. It is assigned to the Default Operation POD (OPERATION_DEF) which uses the 3 panel horizontal layout. If you need to set up a new LOG NC Client, NC Client Maintenance provides a lot of flexibility in configuring the client. See *NC*

SAP ME How-To-Guide for Nonconformance

Client Maintenance, Setting Up Operation and Work Center PODs and POD Maintenance in SAP ME 6.0 Help.

Best Practices – We recommend using the following Operation POD definition that has proven effective for Production Operation processing and Log NC. It is described in the following tables and may be a good starting point. It uses the 3 panel horizontal layout.

Main Tab – NC Client – LOG_NC

Buttons Table - This table represents the data on the Buttons tab.

Button Label	Button Type	Activity
I18N[start.default.BUTTON]	Normal	PR500
I18N[complete.default.BUTTON]	Normal	PR510
I18N[signoff.default.BUTTON]	Normal	PR520
I18N[workinstructions.default.BUTTON]	Normal	WI_LIST_DISPLAY
I18N[assemblyPoint.default.BUTTON]	Normal	COMP_LIST_DISPLAY and CT500
I18N[DCCollect.default.BUTTON]	Normal	DC_LIST_DISPLAY and DC500
I18N[logNC.default.BUTTON]	Normal	NC_SELECTION and NC_DATA_ENTRY
I18N[ncTree.default.LABEL]	Normal	NC_TREE
I18N[toolList.default.BUTTON]	Normal	TOOL_LIST_DISPLAY and LOG_TOOL
I18N[activities.default.BUTTON]	Group	See Activities Table
I18N[reports.default.BUTTON]	Group	See Reports Table

Activities Table – These activities are included under the Activities button:

Activity ID	Description
CT510	As-Built Configuration
GHG_EQUIP_STATUS	Change Equipment Status
PR555	Collect Parent Serial Number
CREATE_MESS_PLUGIN	Create Message
LOG_COMMENT	Log Comment
PR550	Serialize
SFC_DATA_ENTRY	SFC Data Entry
SU520	SFC Place Hold
SU530	SFC Release Hold
DC550	Data Collection Standalone

SAP ME How-To-Guide for Nonconformance

Reports Table – These reports are included under the Reports button:

Activity ID	Report Name
TR700	Activity Log Report
CT700	As-Built Summary Report
BUYOFF_REPORT	Buyoff Report
DM710	Comment Report
SU750	Hold Report
NC700	NC Log Report
DM700	SFC Report
DM730	Shop Order Report

Layout Table – This table represents the data on the Layouts tab:

Panel	Type	Default Plug-in	Other Plug-ins
A	Fixed	WORKLIST_DISPLAY	TOOL_LIST_DISPLAY, WI_LIST_DISPLAY, COMP_LIST_DISPLAY, DC_LIST_DISPLAY, and NC_SELECTION
B	Fixed		
C	Fixed		LOG_TOOL, WI500, CT500, DC500, and NC_DATA_ENTRY
D	Popover		NC_TREE
	Pop-up		All above activities and reports

6 Log NC Reject

6.1 Use

Log NC Reject is an activity similar to Log NC but does not have the full functionality since it is not needed for A&D.

1. This activity is a separate plug-in from the Log NC activity. It is configured as a default NC client with only the NC Data Entry Panel.
2. Multiple SFC is not supported in this activity. An error will be displayed in the message area of the POD when multiple SFC numbers are selected.
3. The buttons displayed in this plug-in are:
 - Reject
 - Close – only when displayed as a fixed plug-in or pop-over
 - Return to POD – only when displayed as a pop-up plug-in

6.2 LogNC_Reject Activity ID

LogNC_Reject is the activity ID. It is not visible in the Activity Manager. The description for this activity is: Log NC Reject.

6.3 Activity Group Assignment

This activity is included in the Product Activity Group.

6.4 Log NC Reject Configuration

The Log NC Reject activity display is defined in POD Maintenance. It can be configured as follows:

6.4.1 Can be defined as a standalone alone button.

In the POD, the Log NC Reject Activity is displayed as either a popover, a pop-up dialogue, or replaces one of the static panels.

6.5 Maintenance Business Rules affecting Log NC Reject

6.5.1 POD Maintenance

The Log NC Reject activity is assigned to a button through Button details only.

6.5.2 NC Code Maintenance

The NC data type used during this activity is defined in NC Code Maintenance in the field "NC Data Type". This data type defines what fields will be displayed on the GUI during logging.

6.5.3 Default NC Code

The default NC Code will be available in any NC Code browse. Therefore, it is available for either the new Log NC Reject activity or existing NC Clients. The activity rule controls the behavior of the Log NC Reject GUI and the NC Code field on this GUI. When the value is either required or optional, the new NC Code called COMMENT will be pre-loaded but can be changed as the NC Code. This code will always have at least one data field called COMMENT that will also be displayed upon entry into the activity.

Below are the details of this NC Code:

Field Label	Field Value
Main Tab	
NC Code	COMMENT
Description	Enter comment
Status	Enabled

SAP ME How-To-Guide for Nonconformance

Assign NC to Component	Stay
NC Category	Failure
DPMO Category	NONE
NC Data Type:	COMMENT
Collect Required NC Data on NC	Open
Message Type	Empty
NC Priority	500
Maximum NC Limit (SFC)	0
Secondary Code Special Instruction	Empty
Can Be Primary Code	Checked
Close Required	Unchecked
Auto Close Primary NC	Checked
Auto Close Incident	Unchecked
Secondary Required for Closure	Unchecked
Disposition Router Tab	
Valid Routers	Empty
Operation/Disposition Group Tab	
Valid Operations	Asterisk (*)
Disposition Group	Empty
Enabled	Checked

NC Groups Tab	
NC Groups	Empty
Secondaries Tab	
Secondaries	Empty
Activity Hooks	Empty
Custom Data	None

6.5.4 Data Type Maintenance

This activity is used to define a specific data type, containing the NC Code data field and other fields and labels that will be displayed to the user, during for use by Log NC Reject. Data Type Maintenance allows the user to specify these fields.

Default Activity Code(s)

The below activity codes will be used for the new default NC Code called COMMENT. Since only Primary NC Codes can be logged in this activity, these will typically be the activity codes that will be specified. However, the existing activity codes for Log NC will continue to be available when using the Log NC functionality.

LOG_FAILURE

- Log Activity Checked

CLOSE_FAILURE

- Log Activity Checked

6.5.5 System Rules

All NC related System Rules apply to the Log NC Reject activity except for Bypass Previous NC Routers on Return. This rule does not apply because no disposition occurs in this activity.

Example:

Work List Selection

1. The user can only select one SFC in the Work List.

Operation Selection

2. The user may only select one operation when using the Log NC Reject activity. If the user chooses multiple operations and then selects the Reject button, it will result in an error display to the operator.

Select Reject Button (Behavior)

3. Only one (1) reject code can be logged at an operation at one time.
4. Only primary NC Codes can be logged in this activity.
5. Disposition Groups and Disposition Routers will not be used in Log NC Reject.
6. Local Rework Disposition is not supported in this activity.
7. When the activity rule is NONE, the system will automatically log the default NC Code "COMMENT". In addition, the system will automatically log the hardcoded comment "Log NC Reject occurred automatically".
8. Reject button will reopen all previously closed buyoffs at the current operation regardless of the user who closed the buyoff.
9. The Times Processed value will only be incremented when the SFC has a Complete Pending status.
10. Appropriate Default Activity Code(s) records will be logged.

6.6 Standalone NC Logging Client

Description

The purpose of the Standalone NC Logging is to provide the users with the ability to log nonconformance's against an SFC without some of the customary validation that is enforced when logging a nonconformance from the POD.

This client is available as a Standalone POD, is independent of and not required to be used through a POD and is accessible through the Activity Manager.

This activity uses all the existing Log NC, and Log NC Reject functionality, through this standalone client.

Note: The general assumption of the Standalone NC Logging activity is that the user will be able to perform selected functions of the Log NC client(s) with respect to the logging of primary and secondary NC codes. Selected disposition options may be supported.

(See also existing functionality as described for Log NC and Log NC Reject above)

7 Links to Additional Information

http://help.sap.com/saphelp_me60/helpdata/EN/40/2db4643b2547379555c562bdbbadb5/content.htm

8 Other Reference Material

Glossary

Log NC – Logging of a nonconformance against a defective part/item/SFC. This function is used typically in a POD configuration or where logging of Primary and Secondary NC Codes is needed to identify defects and their failure or repair codes.

Log NC Reject - Simplified version of logging an NC. This is used generally in the Work Center POD configuration and allows a user to Log a Reject Code against a defective SFC.

Primary NC Code – NC Code used to identify what the major defect (or failure) is on an item.

Secondary NC Code – NC Code used to identify more granularity of the defect on the defective item or the Repair code to “fix” the defective item.

NC Client – This is what the end user sees when configured to be displayed in a POD, for example, the NC Data Entry plug-ins and NC Selection plug-ins.

NC Data Entry – Plug-in designed to allow a user to enter data specific to the NC Code logged against a defect. For example: NC Code, Failure ID, Comment, Ref Des etc.

NC Selection – Plug-in designed to allow a user to select from a list, the desired Primary Code to “log” against a defective item. The Selection area refreshes and displays a list of Secondary Codes when the Primary is selected from the NC Tree, and allows the user to log a secondary defect code or repair code against the item, if the NC Client allows for Primary and Secondary Codes to be logged.

NC Tree – Plug-in designed to show the NC’s in a Tree structured hierarchical format, where the Primary logged NC is the top node and Secondary and repair NC’s logged are children nodes to the parent primary.

Defect- A specific condition of a material, or a material component or feature, which caused or contributed to a Failure

Failure- An event caused by a material, or a material component or feature, not passing a test or an inspection.

Repair- Action taken to address, or disposition, an NC Code logged for a Defect or a Failure.

9 Overview of Changes

This overview describes Log NC Activity for ME 6.0. The approach for the t Log NC plug-in was to create separate plug-ins for the current components of the LOG NC plug-in.

CURRENT LOG NC CONFIGURATION

Current Components of Log NC Plug-in

1. NC Tree
2. NC Selection – contains NC Group List and NC Code List
3. NC Data Entry – composed of NC data fields
4. Ref des List
5. Component List
6. Failure History Chart
7. PCAD Viewer
8. Edit Tab
9. As Built Link

Other Log NC Plug-in Configurations

1. Log NC Reject
 - This activity is a separate plug-in from the Log NC activity. It is configured as a default LOG NC client with only the NC Data Entry Panel.
 - It continues with current behavior as defined in the Log NC Reject.
 - Multiple SFC is not supported in this activity. An error is displayed in the message area of the POD when multiple SFCs are selected.
2. Standalone NC Logging

New Log NC Plug-in Configuration

1. NC Data Tree – renamed from Failure Data Tree
 - Is a combination known as a tree table.
 - AI - Interaction between the NC Data Tree, Failure History Chart and NC Data Entry plug-ins.
 - The NC Data Tree and Data Data Entry plug-in have a two-way communication between each other.
 - a. The NC Data Tree operates off the SFC Selection model and always works off the first SFC to display the contents of the NC Data Tree. This applies to multiple SFCs as well since the validations occur before the NC Data Tree is displayed.
 - List Maintenance
 - a. Columns contained in the tree continue to be configured in List Maintenance.
 - b. The column name field does NOT show the database column but conforms to the display the other lists are using.
 - c. The Category in List Maintenance to support this list has been re- named from NC to NC Tree.
 - d. The default columns for NC Tree (NC_TREE) List are:
 - i. NC Code
 - ii. NC State
 - iii. Operation
 - iv. Resource
 - v. Ref Des

SAP ME How-To-Guide for Nonconformance

- vi. Component
 - vii. Action Detail Icon
 - viii. Edit
 - e. A checkbox is added, labeled Allow Multiple NC Selection and the default value will be checked. This allows control if the user has the ability to select multiple NC Codes in the NC Data Tree.
2. NC Selection – contains NC Group List and NC Code List
3. NC Data Entry –
Displays the NC data fields that are assigned to the NC Data Field Assignment.
 - a. Uses current NC500 as activity id
 - b. Current NC Code field is controlled by a checkbox in NC Client Maintenance. Always displays this field with a browse as the first field in the Data Entry plug-in.
 - c. Ref Des List – becomes standard data type field with browse supporting multiple ref des selection
 - d. Component List – becomes standard data type field with browse supporting multiple component selection.
 - e. Use sthe new data field definition and use the new data field support list type
 - f. Uses the new data field assignment
4. Failure History Chart
 - a. Dependent upon NC Code logged or NC Data Tree
 - b. Failure ID is main drive of Chart
 - c. No longer be tied to VTR. Can be defined as a plug-in for any NC Client.
5. VTR Viewer
 - a. The VTR contents work similarly to the validations performed for the NC Data Tree for the VTR plug-in.
6. Edit Tab
 - a. Replaced with an Edit button that is displayed in the NC Data Tree plug-in.
 - b. Becomes a checkbox in NC Client on the NC Data Tree tab that will control if the button is displayed. The checkbox is labeled “Allow Edit”. The default value is NOT checked.
 - c. The view option is supported via the “action details icon”, which is a column that can be configured in List Maintenance.
7. As Built Link Location
 - a. The current drop down is replaced with a checkbox.
 - b. Displayed on the Main Tab in NC Client Maintenance.
 - c. It will only be displayed in the Data Entry Plug-in to the left of the NC Data Fields.

Log NC Client Button Labels

1. Each plug-in used in Log NC will have a close button.
2. NC 500 – Data Entry will continue with same button labels:
 - Add – always displayed
 - Add/Done – configurable in NC Client to be displayed or not displayed
 - Cancel – always displayed
 - Done – always displayed
3. Log NC Reject
 - Reject
 - Close – only if displayed as fixed plug-in or pop-over
 - Return to POD – only if displayed as pop-up

Specific Log NC Plug-in Behavior in POD

- Panel A will expand vertically down if other panels do not have a default activity defined.
- The horizontal bottom panel size algorithm will always be divided according to the number of panels that are currently displayed.

Multiple SFC Selection Support

- All existing validations will continue to be supported.
- If all validations pass then the checkbox “apply to all” will appear in the Data Entry plug-in and will be checked.
- If all validations do not pass, then the Log NC plug-in will continue to work as it does today where the Log NC client will be changed to single selection mode.

Operation POD Log NC Configuration

1. Contains a default Log NC button
2. The NC Data Tree will replace Panel A whose default value is the Active Work List which is a fixed panel
3. The NC Selection will be displayed in Panel B. This plug-in will contain two action buttons – Log NC and Close.
 - Upon select of Log NC, Panel C will pop-over and will display the NC Data Entry plug-in.

NC CLIENT MAINTENANCE

Current Tab Title

1. Main
2. Basic Log NC (FBI)
3. Advanced Log NC
4. PCAD/D2B
5. Work Instructions

New Tab Title

1. Main
2. NC Selection
3. NC Data Tree
4. NC Data Chart
5. Work Instruction

Key Fields

1. Site – required field and is read only
2. NC Client required field with browse

SAP ME How-To-Guide for Nonconformance

Fields Removed from All Current Tabs of NC Client Maintenance

1. **Main Tab - Display Ref Des Add Panel** (applies to Advanced Log NC & PCAD) – will be supported through the NC Data Field with a browse that will support multiple selection
2. **Main Tab - NC Code Description Tool Tip** – this tool tip will always be shown
3. **Basic Log NC (FBI)** – Display NC Report Button checkbox – this report will be added as default report on the Reports button of the POD
4. **Advanced Log NC and PCAD/D2B - Display NC Code Field for input** – all NC Clients will display the NC Code field as the first field in the NC Data Entry plug-in as the first field
5. **Advanced Log NC** – Display NC Tree Checkbox – will be supported as a plug-in.
6. **Advanced Log NC** – Show Select NC Batch Button – will be replaced by a checkbox in list Maintenance labelled “allow multiple NC Selection”. The default value will be checked.
7. **Advanced Log NC and PCAD/D2B**– Split GUI Vertical – can be replaced by using different POD Layout.
8. **PCAD/D2B** – Allow IPass, Allow FPass, Allow Scrap checkboxes – button configuration now through POD Maintenance/Buttons Tab. Default POD Maintenance button configuration to support these should be the following: Start, Complete, Pass, Log NC
9. **PCAD/D2B** – Log Failure, Log Defect, Log Repair drop-down will be controlled by NC Code and Log Secondary options.
10. **PCAD/D2B** – Layout Embedded, Schematic Embedded, World View Embedded checkboxes will be supported and controlled by the new Viewer.

Main Tab Contents & Default Values upon initial Entry

1. **From Main - Description** – default is blank
2. **From Main - Incident Number drop down** – default value is None
3. **From Main - Preload NC Field drop down** – default value is Both
4. **From Main - Select Default NC Code checkbox** – default value is checked
5. **From Main - Display Combined Add-Done button checkbox** – default value is unchecked
6. **From Main - Do disposition** – default value is checked
7. **From Main - Auto Remove/Replace NC Components** – default value is unchecked
8. **From Main - Component Disposition Routing** – default value is PMR
9. **From Main - Can Log Primary NC Code Checkbox** – default value is checked
10. **From Main - Can Log Against Closed NC Code Checkbox** – default value is checked
11. **From Main - Can Log Secondary NC Code Checkbox** – default value is unchecked
12. **From Main - Prompt to Log Secondary Code Checkbox** – default value is unchecked
13. **From Main - As-Built Link Checkbox** (replaces As-Built Link Location drop down) – default value is unchecked
14. **From Main - Display Work Instruction Button Checkbox** – default value is unchecked

New Tree Tab Contents & Default Values upon initial Entry

1. **From Main - NC Data Tree List** (replaces NC List label) and is required and blank with browse
2. **From Main - Expand NC Data Tree** (replaces NC Tree) checkbox – default value is unchecked
3. **From Main - Allow Edit Checkbox** (replaces Edit tab drop down) – default value is unchecked
4. **From Main - Display Close All Open NCs Button Checkbox** (replaces Show Close All NC Codes Button checkbox) – the default value is checked. The button label is Close NCs

New NC Data Chart Tab Contents & Default Values upon initial Entry

1. **From Main - Display Component/Description on Chart checkbox** – default value is unchecked
2. **From Main - Number of Verified Defect bars** – default value is 5

SAP ME How-To-Guide for Nonconformance

New NC Selection Tab Contents & Default Values upon initial Entry

1. **From Main** – NC Code Display Criteria drop down – default value is NC Code
2. **From Main** – NC Group Column Heading – default value is NC Groups
3. **From Main** – NC Code Column Heading – default value is Available NC Codes
4. **From Main** – NC Code Description in List Checkbox – default value is unchecked

Existing Work Instruction Tab Contents & Default Values upon initial Entry

1. Should be modified to use standard maintenance table display upon initial entry. This means the menu bar should be displayed along with the table header columns.